

SCIENCES AND TECHNOLOGY

1

**DESIGN AND IMPLEMENTATION OF A DC TO DC BUCK CONVERTER USING
TYPE III COMPENSATOR**

BY

**ENGR. (MRS) IRENE .U. UKAZU, Technical Education Department, Federal College of
Education Pankshin**

AND

**MR. JANGIKAM, SELBOL MIRI, Technical Education Department, Federal College of
Education Pankshin**

Abstract

DC- DC converter are power electronics circuits that convert a de voltage to a different dc voltage level, often providing a regulated output. In ideal switching DC - DC converters, the output voltage is a function of the input voltage and duty ratio. In real circuits with non-ideal Components; the output is also the function of the local current because of resistance in the components. A power supply output is regulated by modulating the duty ratio to compensate for variations in the input or load. A feedback control system for power supply control compares output voltage to a reference and converts the error to a duty ratio. This paper focuses on design and implementation of Dc - DC buck converter using type III components

Introduction

DC - DC POWER Converters are electronics devices employed whenever we desire to change DC electrical power efficiently from one voltage magnitude to another. They are useful because unlike Ac, Dc cannot simply be stepped up or down using a line frequency transformer. In many ways a DC to DC Converter is the DC equivalent of a line transformer. The single input to a system is transformed to a different voltage levels useful for operating different components of the system.

DC - DC converters (Regulators) form the backbone of different portable electronic devices like cellular phones, laptops, mp3 players which uses batteries as their power supply. Portable devices usually comprise with different voltage levels which are not the same as battery's voltage level, which is the main supply, Donald and Jorge (2006).

Employing DC - DC Converter can be offered as a method to generate multiple voltage levels from a single DC supply voltage to feed the different sub-circuits in the device This method of generating multiple voltage levels from a single battery source can reduce the device area substantially. On the other hand, DC voltage provided by battery or rectifier contains high voltage ripples and it is not constant enough, thus it is not applicable for most devices. DC- DC regulators are employed to alternate the ripples regardless of change in the load current or input voltage, Chester Simpson (2012).

Statement of the Problems

Over the years as the portable electronics industry progressed, different requirements evolved such as increased battery lifetime, small and cheap system, brighter, full colour displays. An ever increasing demand from power systems has placed power consumption at a premium. To keep up with these demands, engineers have worked towards developing efficient conversion

technique and also have resulted in the subsequent formal growth of an interdisciplinary field of power electronics. However, it comes as no surprise that this new field has offered challenges owing to the unique combination of three major disciplines of electrical engineering: electronics, power and control.

Purpose of the study

The major purpose of this paper is to design and implement a 24v to 19v DC- DC buck converter using pulse with modulation (PWM) in order to achieve the above aim, the following

Objectives are expected to be achieved:

- i. To design a switching circuit for pulse with modulation (PWM)
- ii. Design and simulate A DC- DC buck converter from 24v to 19V.
- iii. Compare the simulated design with diagram laboratory implemented design.

Buck Converters

Buck converters is a type of switching - mode power supply which is used for stepping down DC voltage level. Switch controller block and power block are two main parts of buck converter's circuit. "It can operate in continuous conducting model (CCM) or in Discontinuous conducting mode (DCM), depending on the wave - form of the inductors current". Daniel Meeks (2008)

A TYPICAL BUCK CONVERTER CIRCUIT

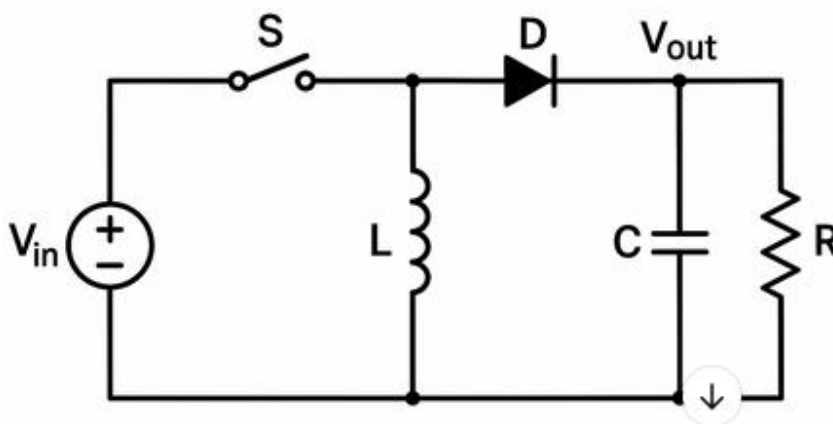

Fig 1 A typical buck converter circuit

Block Diagram of a Buck Converter

Under it fig 2: Block diagram of a DC power processor and feedback control part.

Power stage of Buck converter

A buck converter is a power converter which steps down voltage while stepping up current from its supply to its output load via the controls which consist of the error amplifier, Comparator and driver.

Error Amplification

The feedback voltage v_f is compared to reference voltage v_{ref} and their differences is amplified by error-amplifier is appear as voltage error v_e at the output of the amplifier.

Comparator stage

The voltage error at the output of the error amplifier is applied to the non -inverting input of voltage comparator. V_e is compared to V_{saw} which is applied to the inverting input of the comparator in order to generate square pulses for controlling switching duty cycle, when the voltage error v_e is higher than v_{saw} , the comparator output goes high whereas if the v_e is lower than v_{saw} , its output goes low to adjust the switching duty cycle.

Driver

The driver acts like current buffer and makes the PWM wave form generated by voltage comparator smoother to turn ON and OFF the MOSFET switch and the divide quickly to avoid dissipation during transition.

Components of Buck Converter Circuit

The buck converter consists of five standard components, they are:

- i. Pulse-width modulating controller
- ii. Transistor Switch (active switch)
- iii. Inductor
- iv. Capacitor
- V. Diode (passive switch)

Buck Converter- Theory of operation

The name "buck converter" presumably evolves from the fact that the input voltage is bucked/chopped or ultenuaded, in amplitude and a lower amplitude voltage appears at the output. A buck converter, or step down voltage regulator, provides non - isolated. Switch mode Dc - DC conversion with the advantages of simplicity and low cost

Fig 2 shows a simplified non - 1solated buck converter that accepts a DC input and uses pulse width modulation (PWM) and switching frequency to control the output of an internal power MOSFET.

An external diode, together with external inductor which serves to filter current ripples and output capacitor which also filters voltage ripples and produces the regulated DC output.

Type I compensator

As can be seen in Figure 3. the first type of compensation is a pure integrator, Op-Amp. If the output voltage of the system is equal to reference voltage (less than reference voltage V_{ref}) then R will be connected between the inverting input of the error amplifier and ground as a voltage to make it closer to reference voltage R_{bias} has no effect on the compensation performance and can be ignored when it is not needed

DIAGRAM OF A TYPE 1 COMPENSATOR

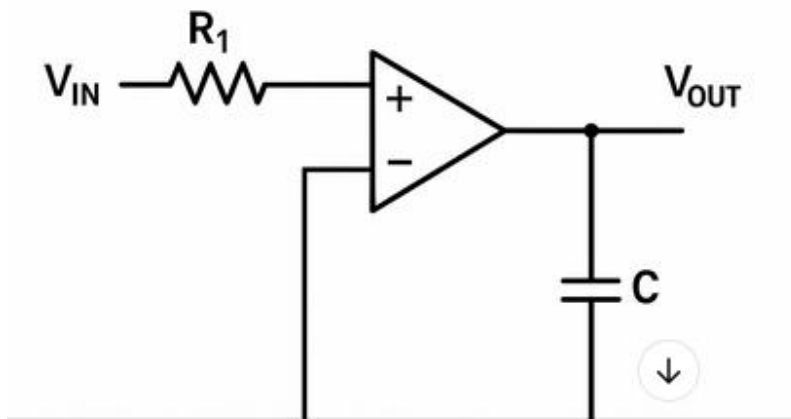
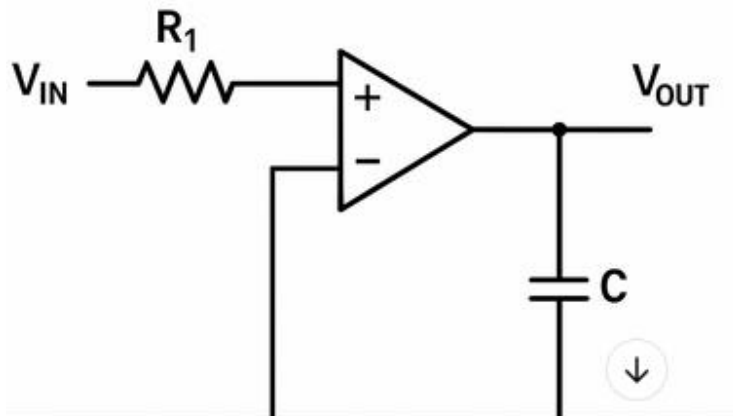

Fig.3 Type I

Network

Diagram of Type II Compensator Circuit

Type 11 compensator which is also called second - order integral - load Controller is depicted in figure 4 below



Type II compensator

The transfer function of type II compensator has a pole at the origin which makes integral part and a single Pole - zero pair that makes the lead part of the compensator. The resistance R , and capacitor C , which provides a pole at the origin from the integral part of compensator circuit.

The capacity C ; and the resistance R_a provide a zero. Also the resistance R and the series combination of capacitor C , and the capacitor C_i provide a pole, the capacitor C ; thus the zero frequency f_z ; is much lower than the pole frequency f_p ; $f_z < f_p$. The purpose of using integral part in compensator circuit is to attain higher gain at low frequencies and at DC in order to reduce DC error but its drawback is reduction of stability in the system. This is due to the fact that the integral controller leads phase shift -90° (phase lag) in all frequencies so far reducing the phase lag between zero and pole frequencies of the system, employing lead compensator is the best system.

The circuit of the type III compensator which is also called third - order Integral lead controller is depicted in figure 5:

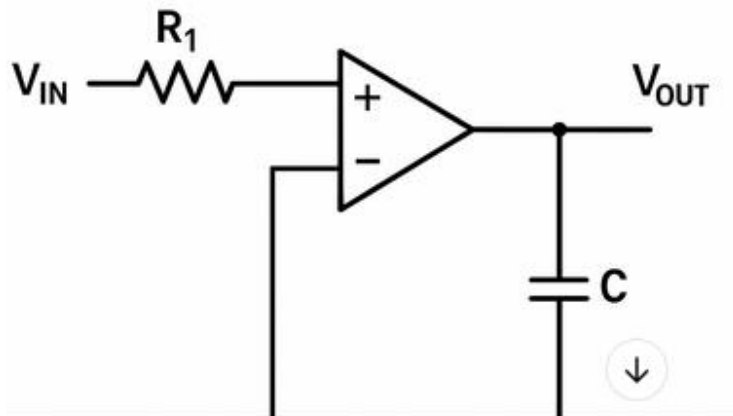

Transfer Function of Type III Compensation

Fig 5 Type III Compensation Network

The transfer function of type III compensator has a pole at origin and two zero - pole pairs. The capacitor C , and resistance R_3 provide a pole at the origin which form the integral part of compensator circuit. The capacitor C , and the resistance R_g together introduce a zero and also the capacitor C_3 and the series combination of the resistance R , and resistance R_3 introduce the second zero. The resistance R , and the series combination of capacitor C_i and the capacitor C , provide a pole. Finally, the capacitor C and the resistance R_3 introduce the second pole of the system.

Continuous Conduction Mode (CCM) and Discontinuous Conduction Mode (DCM)

Buck converter can operate in two different mode; Continuous Conduction Mode (CCM) and Discontinuous Conduction Mode (DCM). The difference between the two is that in CCM, inductance current never falls to zero during discharge interval but in DCM due to low load current, the inductor current falls to zero.

A buck converter operates in continuous conduction mode if the current through the inductor never falls to zero during the commutation cycle.

Fig 6. Continuous Conduction Mode operation of a buck converter

In DCM, the current through the inductor falls to Zero during part of the period. Practically converters can be operated in either operation modes.

Fig.7 Discontinuous Conduction Mode Operator of a buck Converter Diagram

Design and Analysis

The design of this buck converter circuit is based on the continuous mode of operation as earlier explained. The continuous mode of operation never allows the inductor current to fall to zero. As a power electronic circuit, the Dc- DC buck converter consists of the following components

- i. Inductor
- ii. Capacitor
- iii. MOSFET Switch
- iv. Diode
- V. Load resistor
- Vi. The Controller Unit
- vi. The Power Supply Unit

To realize these elements for circuit consumption, certain assumptions and quantities specifications are necessary. The design of these components shall base on the various equations generated in type I, II, and III compensation.

DC- DC Buck Converter Specification.

There are so many factors to be taken into account for designing DCDC converters like power efficiency, transient response, setting time, output voltage ripples, stability of system and occupied area on the chip. For instance, faster transient response can be achieved by increasing frequency but on the other hand higher frequencies causes lower efficiency, therefore, there is always trade- off between transient response of the system and efficiency of converter.

The specification for designing the DC-DC buck converter is according to table 1

Design Specifications

Input voltage

Output voltage

Output Current Range

Output Power

Switching Frequency

Allowed Current Ripple (Peak to Peak) %

Output capacitor ESR

Indicator DCR (ne resistance)

Reference Voltage (Vref)

Table 1 Buck converter specification

Type III Compensator's Components Value

Components

R

R2

R3

Current.

C1

C2

C

V saw

Vret

Table type III compensator's calculated components

For positioning the poles and zero at the desired places to have enough phase margins, the components value of type II Compensator is calculated according to table 2:

Table 2 shows the calculated components value of type III Compensators

K- factor

24v

19v

3.5A

66.5w

30KHZ

15%

10m2

2 m2

19v

Calculated values

2.2 kS2

5.9k2

38.892

34.22f

0.62f

90f

Values

2v

19v

57.7

Conclusion

De- DC Converter are power electronic circuits that convert a DC voltage to a different DC voltage level, often providing a regulated output. The circuits describe are classified as switched mode DC- DC converter circuit that are used in many DC power supply design. Buck converter using type III compensator switching - mode power supply is used for stepping down Dc voltage level. It can operate in Continuous Conduction Mode (CCM) or in Discontinuous Conduction Mode (DCM), depending on the wave form of the conductor current.

References

Chu- Hisiang Chia, Pius- Sunlei, Robert Chen -- Hao Chang (2011). A efficiency PWM DC- DC buck converter with a novel DC light load.

Donald Schelle, Jorge Castorene (2006) "Buck - Converter Design

Daniel Meeks (2008). Loop stability Analysis of Voltage Mode Buck regulator

Different Output Capacitor Types - continuous and Discontinuous

Instruments Inc. Application Report SLVA 301, Texas electronics technology.

Doug Mattingly (2003) "Designing Stable Compensation Networks for Voltage Mode Buck Regulators". Technical Brief Inc.

Maxim Integrated Products, Inc. (2007) "An introduction to Switch - Mode supplies," Application note 4087. high

Sipex Corp (2006). "Selecting appropriate Compensation: Type - II or Type Application Note ANP 18. R.

www.exe.com/common/content/Document-ash? ?d-1241, accessed: Control under

Victor (2012) Power Technologies DC - to- DC Converter"

<http://www.victorpower.com/knowledge-base-php>, accessed Demystified" Powe TB417.1, Intersil Americas

Venable Instrument "Optimum feedback Amplifier design for Control systems"

<http://www.venable.biz/tp-03.pdf> accessed: March 2012.